

RECOMMENDED PCB LAYOUT
 COMPONENT SIDE
 ALL DIMENSION TOLERANCE ARE ± 0.05 mm
 UNLESS OTHERWISE SPECIFIED

RoHS Compliant

				TOLERANCE		 <small>1015 GRANT STREET S.E. ATLANTA, GA 30315</small> <small>a Genesis Electro-Mechanical Company</small>		TITLE: RJ45 1x1 W/ TRANSFORMER Tab Up 10/100/1000 BASE-T W/ LED			
				LINEAR	ANGLES			PART NO. MG45-T01D-R13-6S3			
				X. ±	X° ±			DWG NO. GTI08-30257			
[B]	CORRECT PLATING OPTION	AXL	10/27/09'	.X ± 0.25	.X° ±	APPD:	MAT'L:	UNITS	SCALE	SHEET	REV
[A]	ISSUED	AXL	7/23/08'	.XX ± 0.13	.XX° ±	CHKD:	FINISH:	MM	NONE	1 OF 4	B
REV	ECN NO.	NAME	DATE	.XXX ±	.XXX° ±	DRWN: AXL	Q'TY:				

NOTES:

1. Materials

1.1 Terminal Parts :

- RJ Terminal : Phosphor Bronze , Thickness=0.30mm
- Finish : (a) Contact Area : Gold 30u"
- (b) Solder tail Area : 100u" min. Tin
- (c) Underplating : 50~100u" Nickel over all

- Input Terminal : Brass , Thickness=0.35mm
- Finish : 100u" min. Tin over 50~100u" min. Nickel
- Module Terminal: Brass, Thickness=0.30mm
- Finish : 100u" min. Tin over 50~100u" min. Nickel

1.2 Plastic Parts :

- Housing : High temp. Thermoplastic , Black,
- Flame Class : UL94 V-0

- 1.3 Coil Case : High temp. Thermoplastic , Black
- Flame Class : UL94V-0

- 1.4 Cover : Thermoplastic, PBT, Black
- Flame Class : UL94V-0

1.5 Shell Parts :

- Shell : Stainless, Thickness=0.20mm
- Grounding Leg : Pre-soldering

2. Operating and Storage Temperature

- Operating Temperature : 0°C TO +70°C
- Storage Temperature : -40°C TO +85°C

3. RJ45 specifications:

- Insulation Resistance: 500 Megaohms Min
- Dielectric Withstanding Voltage: 1000VAC Min

4. Performance and Test Description

Product is designed to meet electrical, mechanical and environmental performance requirements specified in below table. All tests are performed at ambient environmental conditions per MIL-STD-1344A and EIA-364 unless otherwise specified.

5. Packaging and Packing

All parts shall be packaged and packed to protect against physical damage, corrosion and deterioration during shipment and storage.

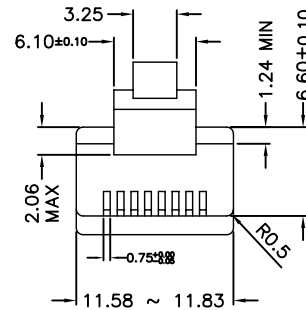

- * There must be no damage to housing or locking latch. There must be no nicks or cuts in cable.
- * Durability : 750 cycles generally

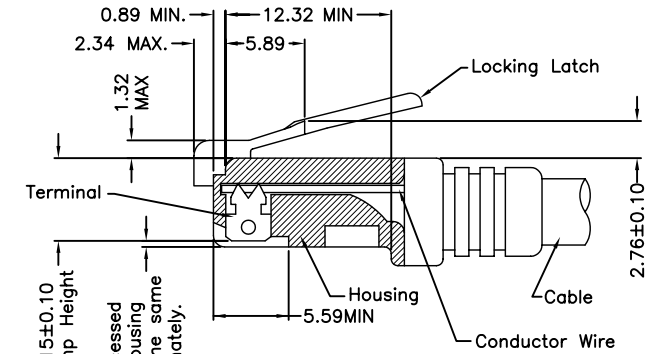

FOLLOW SPECIFICATION : FCC, PART 68,
SUBPART F FIGURE 68.500 (C)(2)(i)
AND IEC 603-7 FIGURE 23 & 24

STANDARD MODULAR PLUG ASSEMBLY

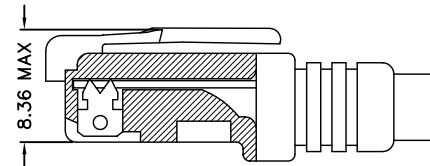

FOLLOW SPECIFICATION : FCC, PART 68, SUBPART F
FIGURE 68.500 (C)(2)(ii)

PART NO.	MG45-T01D-R13-6S3	SHEET	REV
DWG NO.	GTi08-30257	2 OF 4	SEE SHEET 1

ELECTRICAL CHARACTERISTICS

1. Schematic: R13

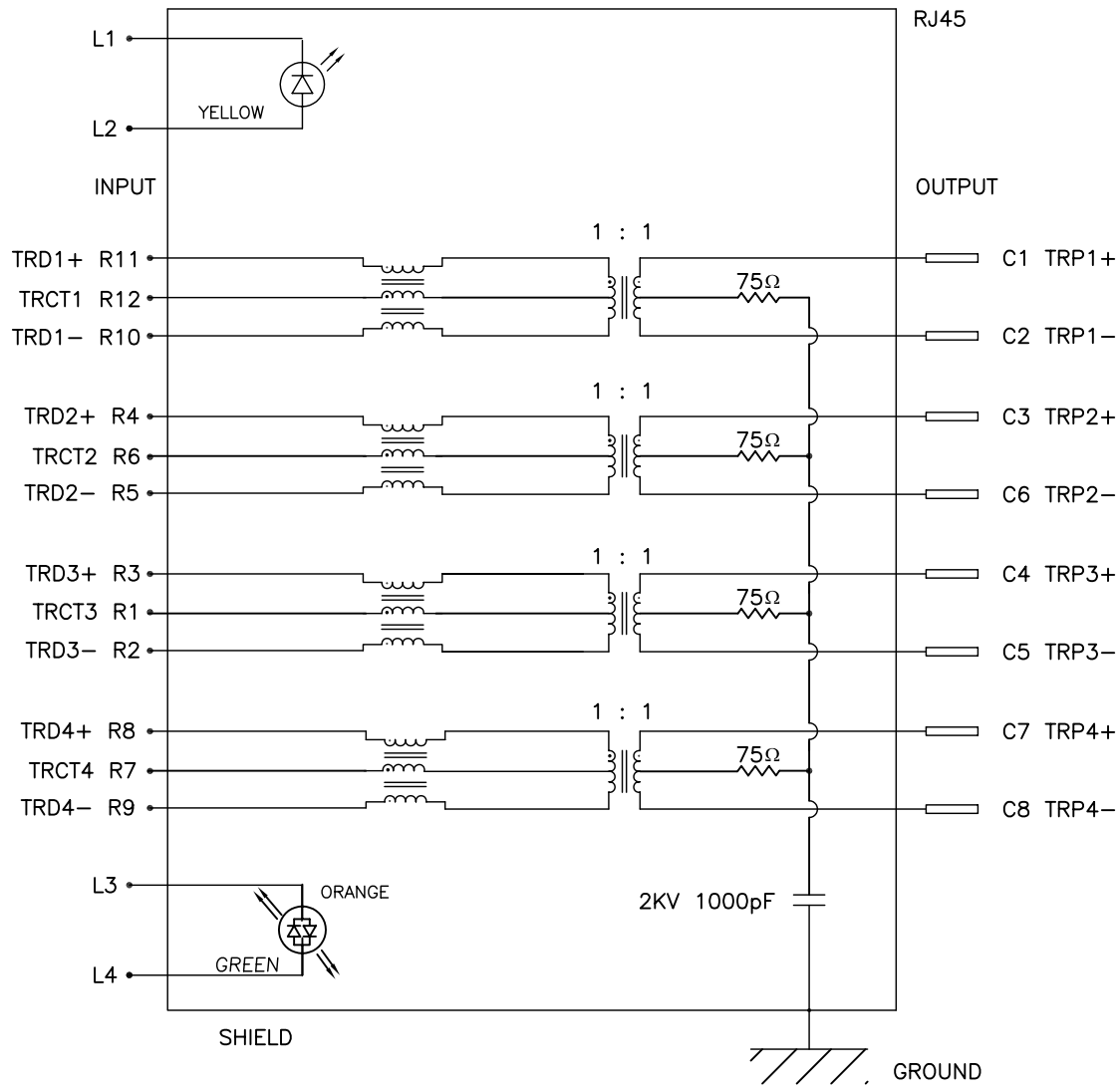

2. Transmitter filter & Receiver filter

Type : Balance low pass 100 ohms impedance

Insertion loss : 1~100 MHz -1.0dB MAX.

Return loss : 1~30 MHz -18dB MIN. load 100 ohms

30~60 MHz -16dB MIN. load 100 ohms

60~80 MHz -12dB MIN. load 100 ohms

80~100 MHz -10dB MIN. load 100 ohms

3. Common Mode Rejection

@ 1~ 100 MHz - 30dB MIN.

4. Cross Talk

@ 1~100 MHz - 30 dB MIN.

5. INDUCTANCE @ 100KHz, 0.1V, 8mA DC BIAS

Input (R11-R10), Input (R4-R5), Input (R3-R2), Input (R8-R9): 350uH MIN.

6. HiPot TEST

Input (R11-R10) to Output (C1-C2) : 1500VAC, 60sec or 2250VDC, 60sec

Input (R4-R5) to Output (C3-C6) : 1500VAC, 60sec, 60sec or 2250VDC, 60sec

Input (R3-R2) to Output (C4-C5) : 1500VAC, 60sec, 60sec or 2250VDC, 60sec

Input (R8-R9) to Output (C7-C8) : 1500VAC, 60sec, 60sec or 2250VDC, 60sec

PART NO.	MG45-T01D-R13-6S3	SHEET	REV
DWG NO.	GTi08-30257	3 OF 4	SEE SHEET 1

Ordering Information:

MG 45-T 01 D- R13 - 6 S3

B

Plating:

S3 = 30u"

Led Configuration: See LED Chart

Schematic Type

Tooling Family

Number of Ports

Mounting Type:

T = R/A tab up

RJ45 Series:

MG = 10/100/1000 Base T

LED CHART

	Left LED		Right LED	
	-L3/+L4	+L3/-L4	-L1/+L2	+L1/-L2
0	w/o	w/o	w/o	w/o
1	Green		Yellow	
2		Green		Yellow
3	Green		Green	Yellow
4	Yellow		Green	
5		Green	Yellow	Green
6	Green	Orange	Yellow	
7	Yellow		Green	Orange
8	Yellow		Orange	Green
9	Green	Orange	Green	
B		Yellow		Green
C	Green		Green	

PART NO.	MG45-T01D-R13-6S3	SHEET	REV
DWG NO.	GTi08-30257	4 OF 4	SEE SHEET 1