

B
Order Information

PART NO.	COLOR		
	OPTO	RCA-1	RCA-2
POF-751-A	GREEN #577 C	BLACK	BLACK
POF-751-B	GREEN #577 C	ORANGE	ORANGE
POF-751-C	GREEN #577 C	WHITE	RED

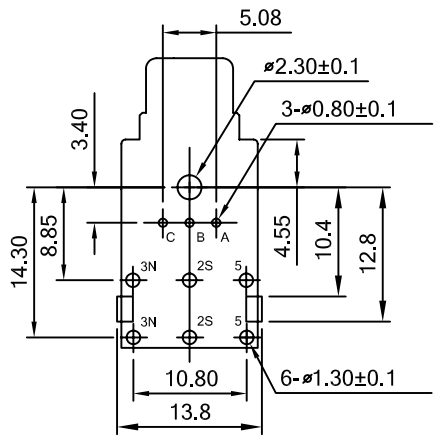

Recommended PCB Layout
<BOTTOM VIEW> Tol.: ± 0.05mm

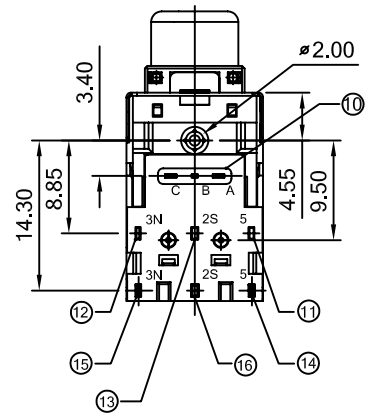

ITEM	DESCRIPTION	MATERIAL	FINISH	QTY'	NOTE
17	SHIELD	BRASS	Ni 30u" MIN	1	
16	CONTACT 2S,RCA-2	BRASS	Tin: 50u" MIN OVER Ni: 30u" MIN	1	
15	CONTACT 3N,RCA-2	PHOSPHOR BRONZE	Tin: 100u" MIN OVER Ni: 30u" MIN	1	
14	CONTACT 2O,RCA-2	BRASS	Tin: 80u" MIN OVER Ni: 30u" MIN	1	
13	CONTACT 2S,RCA-1	BRASS	Tin: 100u" MIN OVER Ni: 30u" MIN	1	
12	CONTACT 3N,RCA-1	PHOSPHOR BRONZE	Tin: 100u" MIN OVER Ni: 30u" MIN	1	
11	CONTACT 2O,RCA-1	BRASS	Tin: 80u" MIN OVER Ni: 30u" MIN	1	
10	DRIVE IC (TX)			1	
9	SPRING,OPTO	SUS 304		2	
8	GATE,OPTO	PA66 + 25% GF		2	#577 C
7	FRAME,OPTO	PA66 + 25% GF		1	
6	GND CONTACT RCA	BRASS	Ni 30u" MIN	2	
5	COLOR RING,RCA	PBT + 30% GF	UL94V-0	2	
4	HOUSING,BASE COVER	PBT + 30% GF	UL94V-0	1	
3	HOUSING,RCA-2	PBT + 30% GF	UL94V-0	1	
2	HOUSING,RCA-1	PBT + 30% GF	UL94V-0	1	
1	HOUSING,OPTO	LCP + 30% GF	UL94V-0	1	

				TOLERANCE		TITLE:	
REV	ECN NO.	NAME	DATE	LINEAR	ANGLES	PART NO.	GTI09-30104
C	ADDED DIMENSION B1 & C2 CORRECTED TOLERANCE CORRECTED NOTES & BOM	FOX	2/17/11	X. ±	X° ± 5°	POF-751-X	GTI09-30104
B	Correct Tol and P/N	AXL	5/5/09'	.X ± 0.30	.X° ± 3°	DWG NO.	GTI09-30104
A	ISSUED	MAX	6/27/06'	.XX ± 0.20	.XX° ±	UNITS	MM
REV	ECN NO.	NAME	DATE	.XXX ±	.XXX° ±	SCALE	NONE
						SHEET	1 OF 4
						REV	C



APPD:	MAT'L:	QTY:
CHKD:	FINISH:	
DRWN: AXL		

C

OPTO Tx

1. GENERAL SCOPE

THE LIGHT RECEIVING UNIT IS A STANDARD-PACKAGED PRODUCT WITH CONNECTOR AND OPTO-ELECTRIC COMPONENT PACKAGED WITH PD AND CONTROL IC. THE FUNCTION OF UNIT CHANGES THE LIGHT SIGNAL TRANSMITTED IN PLASTIC FIBER INTO ELECTRIC SIGNAL. THIS UNIT CAN OPERATE AT DUAL +3.3V ~ +5V AND THE OUTPUT SIGNAL IS TTL COMPATIBLE WITH HIGH PERFORMANCE AT LOW DISSIPATION CURRENT. THE MODULE HAS A MAXIMUM OPERATING SPEED OF 13.2 Mbps. WITH BUILT-IN THRESHOLD CONTROL, THE NOISE MARGIN IS WELL IMPROVED.

2. ELECTRICAL OF TRANSMITTING UNIT

1. ABSOLUTE MAXIMUM RATING

PARAMETERS	SYMBOL	RATING	UNIT
SUPPLY VOLTAGE	V _{DD}	-0.5 ~ +7.0	V
INPUT VOLTAGE	V _{IN}	-0.5 ~ V _{DD} + 0.5	V
POWER DISSIPATION	P	120	m WATT
OPERATING TEMPERATURE	T _{opr}	-20 ~ +70	°C
STORAGE TEMPERATURE	T _{stg}	-40 ~ +70	°C
SOLDERING TEMPERATURE	T _{sol}	260	°C

SOLDERING TIME ≤ 10 SECONDS

2. RECOMMENDED OPERATING CONDITION

PARAMETERS	SYMBOL	MIN	TYP	MAX	UNIT
SUPPLY VOLTAGE	V _{DD}	2.75		5.5	V
HIGH LEVEL INPUT VOLTAGE	V _{IH}	2.0			V
LOW LEVEL INPUT VOLTAGE	V _{IL}			0.8	V

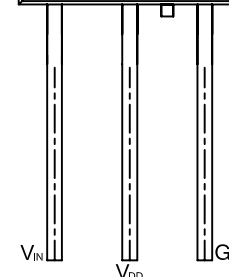
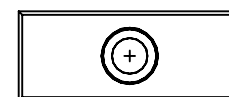
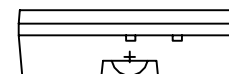

PART NO.	POF-751-X	SHEET	REVISION
DWG NO.	GTi09-30104	2 OF 4	SEE SHEET 1

C

3. ELECTRICAL CHARACTERISTICS (5.0V / Ta=25°C)

Parameters	SYMBOL	CONDITIONS	MIN.	TYP.	MAX.	Unit
TRANSMISSION DISTANCE	D	Using APF	0.2		20	m
OUTPUT POWER	P _f		-21	-17	-15	dBm
CENTER EMISSION WAVELENGTH	λ		630		690	nm
HIGH LEVEL INPUT VOLTAGE	V _{IH}	V _{DD} =3V or 5V	2.0			V
LOW LEVEL INPUT VOLTAGE	V _{IL}	V _{DD} =3V or 5V			0.8	V
QUIESCENT SUPPLY CURRENT	I _{OUT_ON}	V _{DD} =3V or 5V V _{IN} = V _{DD} V _{FLED} =2.0V		6	10	mA
OUTPUT LEAKAGE CURRENT	I _{OUT_OFF}	V _{DD} =3V or 5V V _{IN} = V _{SS} V _{FLED} =2.0V				μA
PROPAGATION DELAY	t _{PLH} t _{PLH}	NRZ Code C _{LED} =30 PF V _{FLED} =2.0V			100	ns
RISE TIME OF I _{OUT}	t	NRZ Code C _{LED} =30 PF V _{FLED} =2.0V			30	ns
FALL TIME OF I _{OUT}	t _f	NRZ Code C _{LED} =30 PF V _{FLED} =2.0V			30	ns
PULSE WIDTH DISTORSION	Δt _w	6 Mbps NRZ Code	-25		25	ns
JITTER	Δt _J				25	ns
DATA RATE	T	NRZ Code C _{LED} =30 PF V _{FLED} =2.0V	DC		13.2	Mbps

APPLICATION NOTE:

1.

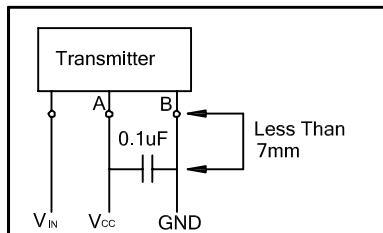

2. TO REDUCE THE DIGITAL NOISE FROM DIGITAL IC ON THE MOTHER-BOARD, THE PLANAR CAPACITANCE FORMED BY A ISOLATED V_{CC} AND GND PLANE IS CRITICAL. THE POF DEVICE MUST BE MOUNTED DIRECTLY ON THOSE TWO PLANES TO REDUCE THE LEAD PARASITIC INDUCTANCE.

PART NO.	POF-751-X	SHEET	REVISION
DWG NO.	GTi09-30104	3 OF 4	SEE SHEET 1

A

A

C

3. MECHANICAL

1. TERMINAL STRENGTH

THE TERMINALS SHALL BE CAPABLE OF WITHSTANDING A FORCE OF 500 GRAMS APPLIED IN ANY DIRECTION FOR 10 SECONDS WITHOUT LOOSING OR BREAKDOWN, EXCEPT BENDING THE TERMINALS.

2. INSERTION FORCE: 0.3 Kgs MAX

3. EXTRACTION FORCE: 3.0 Kgs MAX

4. ELECTRICAL

1. WITHSTAND VOLTAGE TEST

500 VOLTS AC/RMS OF COMMERCIAL FREQUENCY 50 TO 60 HZ APPLIED BETWEEN ADJACENT OPEN TERMINALS FOR 1 MINUTE WITHOUT BREAKDOWN.

2. INSULATION RESISTANCE

THE INSULATION RESISTANCE BETWEEN MUTUAL INSULATED CONTACTS SHOULD BE COMPLIED WITH THE FOLLOWING SPECIFICATION UNDER 500 VOLTS DC.

3. CONTACT RESISTANCE: 50mΩ MAX

5. ENVIRONMENT:

1. DURABILITY: THE DURABILITY TEST SHALL CONSIST OF 5000 & 500 MATING CYCLES OF INSERTION AND EXTRACTION WITH THE MATED PLUG OR THE GAUGE PLUG AT A RATE 10 ~ 20 CYCLES (TYPICAL) PER MINUTE.

2. HUMIDITY TEST: AT THE CONDITION OF 40°C ± 2°C AND THE RELATIVE HUMIDITY OF 90% TO 95% RH FOR 96 HOURS THEN PLACE IN AMBIENT TEMPERATURE FOR MORE THAN 30 MINUTES

3. HEAT TEST: AT THE CONDITION OF 85 ± 2°C AND THE RELATIVE HUMIDITY OF LESS THAN 50% RH FOR 96 HOURS. THEN PLACE IN AMBIENT TEMPERATURE FOR MORE THAN 30 MINUTES

4. COLD TEST: AT THE CONDITION OF 40 ± 2°C FOR 96 HOURS. THEN PLACE IN AMBIENT TEMPERATURE FOR MORE THAN 30 MINUTES

5. OPERATING TEMPERATURE: -25°C TO 70°C

6. STORAGE TEMPERATURE: -25°C TO 70°C

6. SOLDER ABILITY: THE TERMINAL OF JACK TESTED SHALL BE DIPPED INTO SOLDERING FLUX OR EQUIVALENT FOR A PERIOD OF 5 TO 10 SECONDS AND THEN IMMERESED INTO MOLTEN SOLDER, Sn, AT A CONTROLLED TEMPERATURE OF 260°C ± 5°C FOR 3 ± 0.5 SECONDS AFTER AGING. THE COVERAGE SHOULD BE MORE THAN 95% BY THE MICROSCOPE OF MORE THAN 10x.

7. THIS SPECIFICATION COVERS THE GENERAL REQUIREMENTS OF THE RCA JACK (PIN JACK) PER EIAJ RC-5231, APPLIED ON AUDIO/VIDEO SYSTEM AND OTHER RELATED ELECTRONIC APPARATUS. ESPECIALLY THIS SPECIFICATION APPLIED ON THE NORMAL PLASTIC FOR THE THROUGH HOLE SOLDERING PROCESS

8. RoHs 6 / 6 COMPLIANT

B

B

C

C

D

D

E

E

PART NO.	POF-751-X	SHEET	REVISION
DWG NO.	GTI09-30104	4 OF 4	SEE SHEET 1