

RECOMMENDED PADS LAYOUT
 <TOP VIEW>
 NOTE: TOLERANCE FOR PCB LAYOUT IS ± 0.05

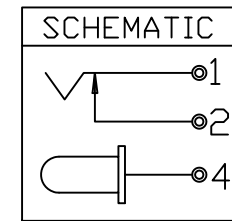

ITEM	DESCRIPTION	MATERIAL	FINISH	QTY	NOTE
5	SUPPORT	SK5M	Tin 80u" Min.	1	
4	PIN CENTER	Brass	Ag. 50u" Min. over 30u" Ni Min.	1	
3	SHUNT	Brass	Ag. 50u" Min. over 30u" Ni Min.	1	
2	SPG CONTACT	Ti Cu	Ag. 50u" Min. over 30u" Ni Min.	1	
1	HOUSING	PA9T+33%GF		1	UL94V-0

				TOLERANCE		TITLE:			
				LINEAR	ANGLES	□1.0mmDC POWER JACK VERY LOW PROFILE			
[C]	UPDATE DRAWING	Kevin	12/09/10	X. ±	X° ±5°	PART NO.	SDC - 259		
[B]	UPDATED INFORMATION	FOX	2/09/09	.X ± 0.3	.X° ±3°	DWG NO.	GTI09-30020		
[A]	ISSUED	JANE	06/26/06	.XX ± 0.2	.XX° ±	CHKD:	FINISH:		
REV	ECN NO.	NAME	DATE	.XXX ±	.XXX° ±	DRWN: FOX	Q'TY:		
						UNITS	SCALE	SHEET	REV
						MM	NONE	1 OF 6	C

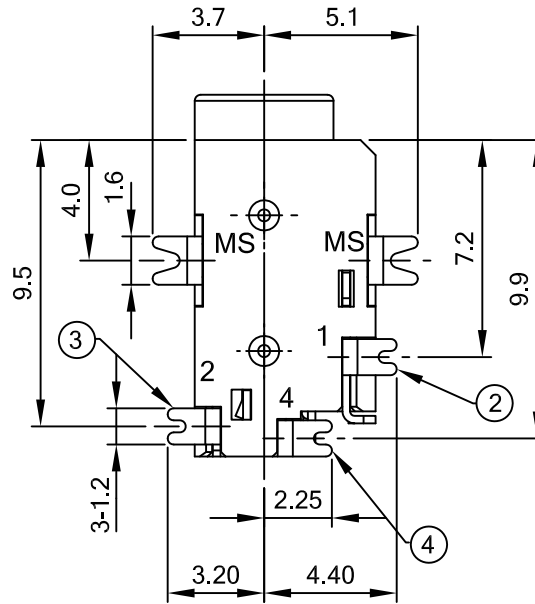

APPD:	MAT'L:
CHKD:	FINISH:
DRWN: FOX	Q'TY:

B SPECIFICATION

1. GENERAL
SCOPE

THIS SPECIFICATION COVERS THE GENERAL REQUIREMENTS OF THE DC POWER JACK APPLIED ON AUDIO SYSTEMS AND OTHER RELATED ELECTRONIC APPARATUS. ESPECIALLY THIS SPECIFICATION APPLIED ON THE HIGH TEMPERATURE PLASTIC FOR THE REFLOW SOLDERING PROCESS.

2. MECHANICAL

2a. TERMINAL STRENGTH

THE TERMINALS SHALL BE CAPABLE OF WITHSTANDING A FORCE OF 500 GRAMS APPLIED IN ANY DIRECTION FOR 10 SECONDS WITHOUT LOSING OR BREAKDOWN, EXCEPT BENDING THE TERMINALS.

2b. INSERTION AND EXTRACTION FORCE
INSERTION FORCE

CONDITIONS	VALUE OF SPEC.
INITIAL CONDITION	0.3 Kgs TO 3.0 Kgs
AFTER LIFE TEST AFTER HUMIDITY TEST AFTER HEAT TEST AFTER COLD TEST AFTER RESISTANCE TO SOLDERING HEAT TEST	0.2 Kgs TO 3.0 Kgs

EXTRACTION FORCE

CONDITIONS	VALUE OF SPEC.
INITIAL CONDITION	0.3 Kgs TO 3.0 Kgs
AFTER LIFE TEST AFTER HUMIDITY TEST AFTER HEAT TEST AFTER COLD TEST AFTER RESISTANCE TO SOLDERING HEAT TEST	0.2 Kgs TO 3.0 Kgs

3. ELECTRICAL

3a. WITSTAND VOLTAGE TEST

500 VOLTS AC/RMS OF COMMERCIAL FREQUENCY 50 TO 60 Hz APPLIED BETWEEN ADJACENT OPEN TERMINALS FOR 1 MINUTE WITHOUT BREAKDOWN

3b. INSULATION RESISTANCE

THE INSULATION RESISTANCE BETWEEN MUTUAL INSULATED CONTACTS SHOULD COMPLIED WITH FOLLOWING SPECIFICATION UNDER 500 VOLTS DC (METHOD C UNLESS OTHERWISE SPECIFIED).

CONDITIONS	VALUE OF SPEC.
INITIAL CONDITION AFTER LIFE TEST AFTER HEAT TEST AFTER COLD TEST AFTER RESISTANCE TO SOLDERING HEAT TEST	100 MΩ MIN.
AFTER HUMIDITY TEST	50 MΩ MIN.
NOTE: THE MATED PLUG USED TO THIS MEASUREMENT SHALL BE ALLOWED TO CLEAN AND REMOVE OXIDATION FILM ON THE SURFACE BEFORE TEST.	

3c. CONTACT RESISTANCE

CONTACT RESISTANCE OF JACK SHALL NOT EXCEED THE VALUE DEFINED IN THE TABLE LISTED AT A CURRENT LESS THAN 1.0 Amp. DC BY FOUR TERMINALS METHOD.

CONDITIONS	VALUE OF SPEC.	
	PLUG TO CONTACTS	CONTACT TO SHUNT
INITIAL CONDITION AFTER HUMIDITY TEST AFTER HEAT TEST AFTER COLD TEST AFTER RESISTANCE TO SOLDERING HEAT TEST	50 mΩ MAX.	30 mΩ MAX.
AFTER DURABILITY TEST	100 mΩ MAX.	60 mΩ MAX.
NOTE: THE MATED PLUG USED IN THIS MEASUREMENT SHALL BE ALLOWED TO CLEAN AND REMOVE OXIDATION FILM ON THE SURFACE BEFORE TEST.		



PART NO.	SDC - 259	SHEET	REVISION
DWG NO.	GTI09-30020	3 OF 6	SEE SHEET 1

4. ENDURANCE

DURABILITY TEST

THE DURABILITY TEST SHALL CONSIST OF 5000 MATING CYCLES OF INSERTION AND EXTRACTION WITH THE MATED PLUG OR THE GAUGE PLUG AT A RATE 10 ~ 20 CYCLES PER MINUTE, NO LOAD CONDITION, WITH OR WITHOUT LUBRICANT WHICH SHOULD BE SPECIFIED THE DETAIL REQUIREMENT. THE PERFORMANCE OF THE JACK BEFORE AND AFTER THIS TEST SHOULD COMPLY WITH PARAGRAPHS 2b AND 3c.

MEASURING CONDITION

ALL MEASUREMENTS AND TEST SHALL BE MADE AT A TEMPERATURE 10° C TO 35° C WITH A RELATIVE HUMIDITY OF 45% RH TO 85% RH UNDER STANDARD ATMOSPHERIC PRESSURE UNLESS OTHERWISE SPECIFIED CONDITIONS.

5. ENVIRONMENT

5a. HUMIDITY TEST

THE JACK SHALL BE PLACED IN THE TESTING CHAMBER AT THE CONDITION OF 40° C ± 2° C AND THE RELATIVE HUMIDITY OF 90% TO 95% RH FOR 96 Hrs, THE DEW DROPS ON THE SURFACE OF JACK SHALL BE BLOWN OFF AND REMOVED FROM THE SURFACE OF JACK AND THEN PLACED IN AMBIENT TEMPERATURE FOR MORE THAN 30 MINUTES RECOVERY PERIOD. THE RELATIVE TEST BEFORE AND AFTER THIS TEST SHOULD COMPLIED WITH PARAGRAPH 3b AND 3c.

5b. HEAT TEST

THE JACK SHALL BE PLACED IN THE TESTING CHAMBER AT A TEMPERATURE OF 70° C ± 2° C AND THE RELATIVE HUMIDITY OF LESS THAN 50% RH FOR 96 Hrs AND THEN PLACED IN AMBIENT TEMPERATURE FOR MORE THAN 30 MINUTES, RECOVERY PERIOD. THE RELATIVE TEST BEFORE AND AFTER THIS TEST SHOULD COMPLIED WITH PARAGRAPH 3c.

5c. COLD TEST

THE JACK SHALL BE PLACED IN THE TESTING CHAMBER AT A TEMPERATURE OF -40° C ± 2° C AND THE RELATIVE HUMIDITY OF LESS THAN 50% RH FOR 96 Hrs AND THEN PLACED IN AMBIENT TEMPERATURE FOR MORE THAN 30 MINUTES, RECOVERY PERIOD. THE RELATIVE TEST BEFORE AND AFTER THIS TEST SHOULD COMPLIED WITH PARAGRAPH 3c.

 <p>GENESIS TECHNOLOGY, INC. 1015 GRANT STREET S.E. ATLANTA, GA 30315 a Genesis ElectroMechanical Company</p>	PART NO.	SDC - 259	SHEET	REVISION
	DWG NO.	GTI09-30020	4 OF 6	SEE SHEET 1

6. SOLDERING TEST

6a. REFLOW PROFILE FOR SOLDERABILITY TESTING

REFLOW PROFILE FOR SOLDERABILITY TESTING:		
Item	Time	Specification
Pre Heating		3° c/ Sec MAX.
Flux Wetting	T soak	2 ~ 3 Min
Time Over 217° C	t1	30 Sec MAX.
Peak Temp	T2	260° C (-0/+5° C)
Peak Time	t2	10 Sec
Speed of Cooling		<6° C/Sec

C

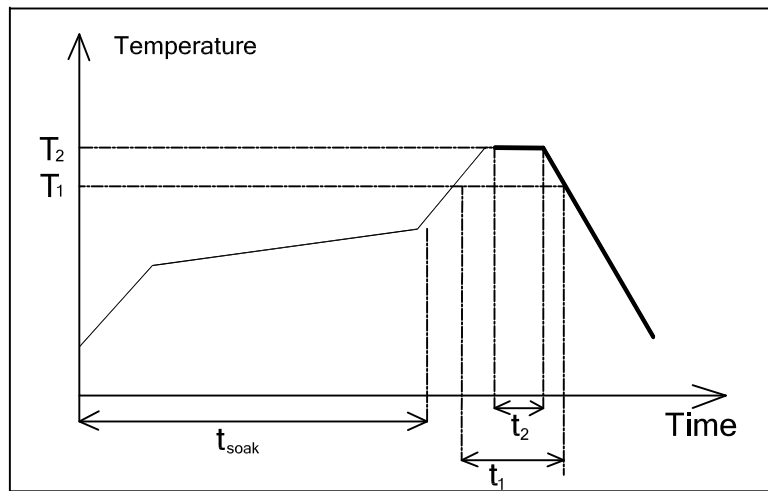

Figure 1. Reflow profile for solderability testing.

6b. RESISTANCE TO REFLOW SOLDERING HEAT

REMOVE SPECIMEN FROM THE MOISTURE SOAK AND STORE AT ROOM TEMPERATURE FOR 15 MINUTES, NO LONGER THAN 4 HOURS AFTER REMOVAL FROM THE TEMPERATURE AND HUMIDITY EXPOSURE, SUBJECT THE SPECIMEN TO 3 CYCLES OF THE FOLLOWING REFLOW PROFILE.

REFLOW PROFILE FOR SOLDERING HEAT RESISTANCE TESTING:		
Item	Time	Specification
Pre Heating		3° C/Sec MAX.
Flux Wetting	T soak	2 ~ 3 Min
Time Over 217° C	t1	60 ~150 Sec
Peak temp	t3	260° C(-0/+5°C)
Peak Time	T peak	10 Sec
Speed of Cooling		6°C/ Sec MAX.
25°C to Peak Temp		8 Minutes MAX.

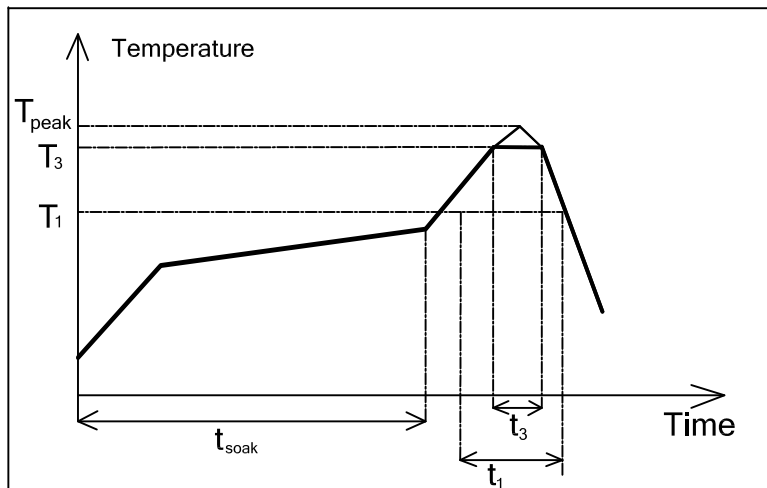

Figure 2. Reflow profile for soldering heat resistance testing

THE OUTLOOK OF THE JACK SHOULD HAVE NO REMARKABLE DETERIORATION. THE RELATIVE TEST BEFORE AND AFTER THIS TEST SHOULD COMPLIED WITH PARAGRAPH 3c.

7. OPERATING TEMPERATURE

THE RANGE : -25 TO +85 °C

8. RATING

RATED VOLTAGE: 12 VOLTS DC

RATED CURRENT: 3.5 AMPERES DC

9. RoHs COMPLIANT